

VOLATILE ORGANIC SAMPLING TRAIN

## 1.0 PRINCIPLE AND APPLICATION

1.1 Principle

1.1.1 This method describes the collection of volatile principal organic hazardous constituents (POHCs) from the stack gas effluents of hazardous waste incinerators. For the purpose of definition, volatile POHCs are those POHCs with boiling points less than 100°C. If the boiling point of a POHC of interest is less than 30°C, the POHC may break through the sorbent under the conditions of the sample collection procedure.

1.1.2 Field application for POHCs of this type should be supported by laboratory data which demonstrate the efficiency of a volatile organic sampling train (VOST) to collect POHCs with boiling points less than 30°C. This may require using reduced sample volumes collected at flow rates between 250 and 500 mL/min. Many compounds which boil above 100°C (e.g., chlorobenzene) may also be efficiently collected and analyzed using this method. VOST collection efficiency for these compounds should be demonstrated, where necessary, by laboratory data of the type described above.

1.1.3 This method employs a 20-liter sample of effluent gas containing volatile POHCs which is withdrawn from a gaseous effluent source at a flow rate of 1 L/min, using a glass-lined probe and a volatile organic sampling train (VOST). (Operation of the VOST under these conditions has been called FAST-VOST.) The gas stream is cooled to 20°C by passage through a water-cooled condenser and volatile POHCs are collected on a pair of sorbent resin traps. Liquid condensate is collected in an impinger placed between the two resin traps. The first resin trap (front trap) contains approximately 1.6 g Tenax and the second trap (back trap) contains approximately 1 g each of Tenax and petroleum-based charcoal (SKC Lot 104 or equivalent), 3:1 by volume. A total of six pairs of sorbent traps may be used to collect volatile POHCs from the effluent gas stream.

1.1.4 An alternative set of conditions for sample collection has been used. This method involves collecting sample volume of 20 liters or less at reduced flow rate. (Operation of the VOST under these conditions has been referred to as SLO-VOST.) This method has been used to collect 5 liters of sample (0.25 L/min for 20 min) or 20 liters of sample (0.5 L/min for 40 min) on each pair of sorbent cartridges. Smaller sample volumes collected at lower flow rates should be considered when the boiling points of the POHCs of interest are below 35°C. A total of six pairs of sorbent traps may be used to collect volatile POHCs from the effluent gas stream.

1.1.5 Analysis of the traps is carried out by thermal desorption purge-and-trap by gas chromatography/mass spectrometry (see Method 5040). The VOST is designed to be operated at 1 L/min with traps being replaced every 20 min for a total sampling time of 2 hr. Traps may be analyzed separately or combined onto one trap to improve detection limit. However, additional flow rates and sampling times are acceptable. Recent experience has shown that when less than maximum detection ability is required, it is acceptable and probably preferable to operate the VOST at 0.5 L/min for a total of three 40-min periods. This preserves the 2-hr sampling period, but reduces the number of cartridge changes in the field as well as the number of analyses required.

## 1.2 Application

1.2.1 This method is applicable to the determination of volatile POHCs in the stack gas effluent of hazardous waste incinerators. This method is designed for use in calculating destruction and removal efficiency (DRE) for the volatile POHCs and to enable a determination that DRE values for removal of the volatile POHCs are equal to or greater than 99.99%.

1.2.2 The sensitivity of this method is dependent upon the level of interferences in the sample and the presence of detectable levels of volatile POHCs in blanks. The target detection limit of this method is 0.1 ug/m<sup>3</sup> (ng/L) of flue gas, to permit calculation of a DRE equal to or greater than 99.99% for volatile POHCs which may be present in the waste stream at 100 ppm. The upper end of the range of applicability of this method is limited by breakthrough of the volatile POHCs on the sorbent traps used to collect the sample. Laboratory development data have demonstrated a range of 0.1 to 100 ug/m<sup>3</sup> (ng/L) for selected volatile POHCs collected on a pair of sorbent traps using a total sample volume of 20 liters or less (see Paragraph 1.1.4).

1.2.3 This method is recommended for use only by experienced sampling personnel and analytical chemists or under close supervision by such qualified persons.

1.2.4 Interferences arise primarily from background contamination of sorbent traps prior to or after use in sample collection. Many potential interferences can be due to exposure of the sorbent materials to solvent vapors prior to assembly and exposure to significant concentrations of volatile POHCs in the ambient air at hazardous waste incinerator sites.

1.2.5 To avoid or minimize the low-level contamination of train components with volatile POHCs, care should be taken to avoid contact of all interior surface or train components with synthetic organic materials (e.g., organic solvents, lubricating and sealing greases), and train components should be carefully cleaned and conditioned according to the procedures described in this protocol.

## 2.0 APPARATUS

2.1 Volatile Organic Sampling Train: A schematic diagram of the principal components of the VOST is shown in Figure 1 and a diagram of one acceptable version of the VOST is shown in Figure 2. The VOST consists of a glass-lined probe followed by an isolation valve, a water-cooled glass condenser, a sorbent cartridge containing Tenax (1.6 g), an empty impinger for condensate removal, a second water-cooled glass condenser, a second sorbent cartridge containing Tenax and petroleum-based charcoal (3:1 by volume; approximately 1 g of each), a silica gel drying tube, a calibrated rotameter, a sampling pump, and a dry gas meter. The gas pressure during sampling and for leak-checking is monitored by pressure gauges which are in line and downstream of the silica gel drying tube. The components of the sampling train are described below.

2.1.1 **Probe**: The probe should be made of stainless steel with a borosilicate or quartz glass liner. The temperature of the probe is to be maintained above 130°C but low enough to ensure a resin temperature of 20°C. A water-cooled probe may be required at elevated stack temperatures to protect the probe and meet the above requirements. Isokinetic sample collection is not a requirement for the use of VOST since the compounds of interest are in the vapor phase at the point of sample collection.

2.1.2 **Isolation valve**: The isolation valve should be a greasless stopcock with a glass bore and sliding Teflon plug with Teflon wipers (Ace 8193 or equivalent).

2.1.3 **Condensers**: The condensers (Ace 5979-14 or equivalent) should be of sufficient capacity to cool the gas stream to 20°C or less prior to passage through the first sorbent cartridge. The top connection of the condenser should be able to form a leak-free, vacuum-tight seal without using sealing greases.

### 2.1.4 Sorbent cartridges:

2.1.4.1 The sorbent cartridges used for the VOST may be used in either of two configurations: the inside-outside (I/O) configuration in which the cartridge is held within an outer glass tube and in a metal carrier, and the inside-inside (I/I) configuration in which only a single glass tube is used, with or without a metal carrier. In either case, the sorbent packing will be the same.

2.1.4.1.1 The first of a pair of sorbent cartridges shall be packed with approximately 1.6 g Tenax GC resin and the second cartridge of a pair shall be packed with Tenax GC and petroleum-based charcoal (3:1 by volume; approximately 1 g of each).

2.1.4.1.2 The second sorbent cartridge shall be packed so that the sample gas stream passes through the Tenax layer first and then through the charcoal layer.

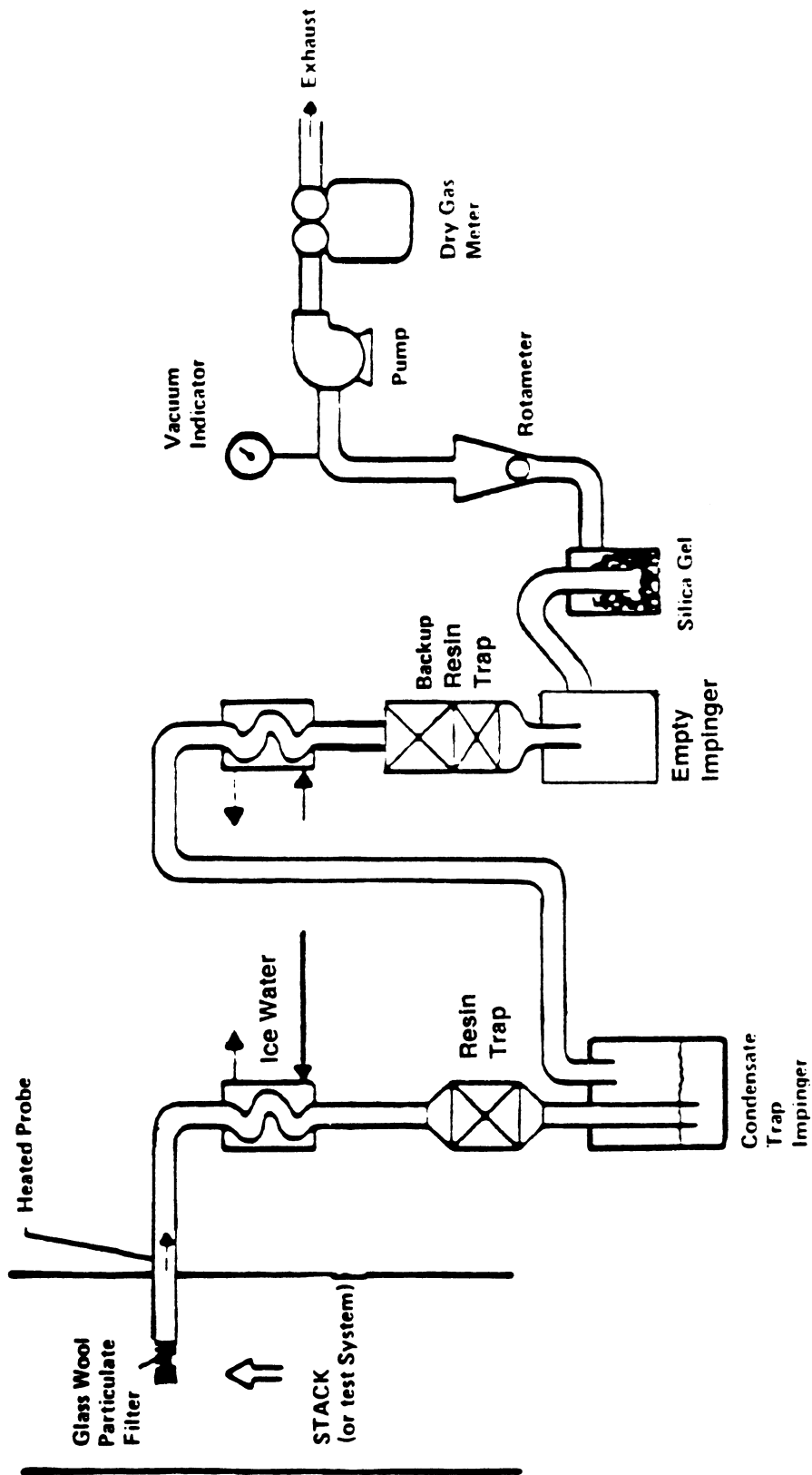

Figure 1. Schematic of Volatile Organic Sampling Train (VOST).

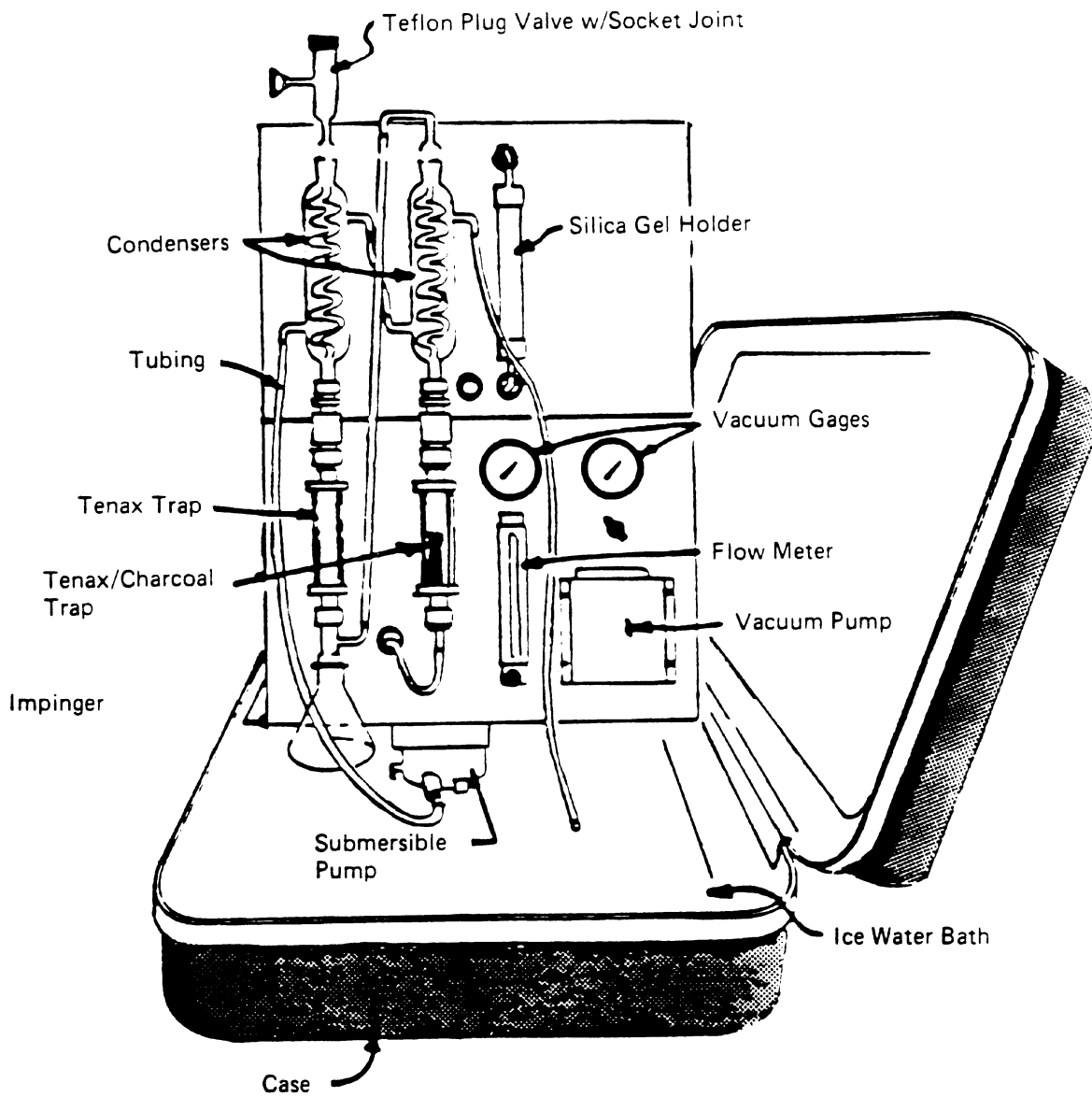

Figure 2. Volatile Organic Sampling Train (VOST).

2.1.4.2 The sorbent cartridges shall be glass tubes with approximate dimensions of 10 cm by 1.6 cm I.D. The two acceptable designs (I/O, I/I) for the sorbent cartridge are described in further detail below.

2.1.4.2.1 **Inside/Inside sorbent cartridge:** A diagram of an I/I sorbent cartridge is shown in Figure 3. This cartridge is a single glass tube (10 cm by 1.6 cm I.D.) which has the ends reduced in size to accommodate a 1/4- or 3/8-in. Swagelok or Cajon gas fitting. The resin is held in place by glass wool at each end of the resin layer. The amounts of each type of sorbent material used in the I/I design are the same as for the I/O design. Threaded end caps are placed on the sorbent cartridge after packing with sorbent to protect the sorbent from contamination during storage and transport.

2.1.4.2.2 **Inside/Outside type sorbent cartridge:** A diagram of an I/O sorbent cartridge is shown in Figure 4. In this design the sorbent materials are held in the glass tube with a fine mesh stainless steel screen and a C-clip. The glass tube is then placed within a larger diameter glass tube and held in place using Viton O-rings. The purpose of the outer glass tube is to protect the exterior of the resin-containing tube from contamination. The two glass tubes are held in a stainless steel cartridge holder, where the ends of the glass tubes are held in place by Viton O-rings placed in machine grooves in each metal end piece. The three cylindrical rods are secured in one of the metal end pieces and fastened to the other end piece using knurled nuts, thus sealing the glass tubes into the cartridge holder. The end pieces are fitted with a threaded nut onto which a threaded end cap is fitted with a Viton O-ring seal, to protect the resin from contamination during transport and storage.

2.1.5 **Metering system:** The metering system for VOST shall consist of vacuum gauges, a leak-free pump (Thomas Model 107 or equivalent, Thomas Industries, Sheboygan, Wisconsin), a calibrated rotameter (Linde Model 150, Linde Division of Union Carbide, Keasbey, New Jersey) for monitoring the gas flow rate, a dry gas meter with 2% accuracy at the required sampling rate, and related valves and equipment. Provisions should be made for monitoring the temperature of the sample gas stream between the first condenser and first sorbent cartridge. This can be done by placing a thermocouple on the exterior glass surface of the outlet from the first condenser. The temperature at that point should be less than 20°C. If it is not, an alternative condenser providing the required cooling capacity must be used.

2.1.6 **Sample transfer lines:** All sample transfer lines to connect the probe to the VOST shall be less than 5 ft in length, and shall be heat-traced Teflon with connecting fittings which are capable of forming leak-free, vacuum-tight connections without the use of sealing grease.

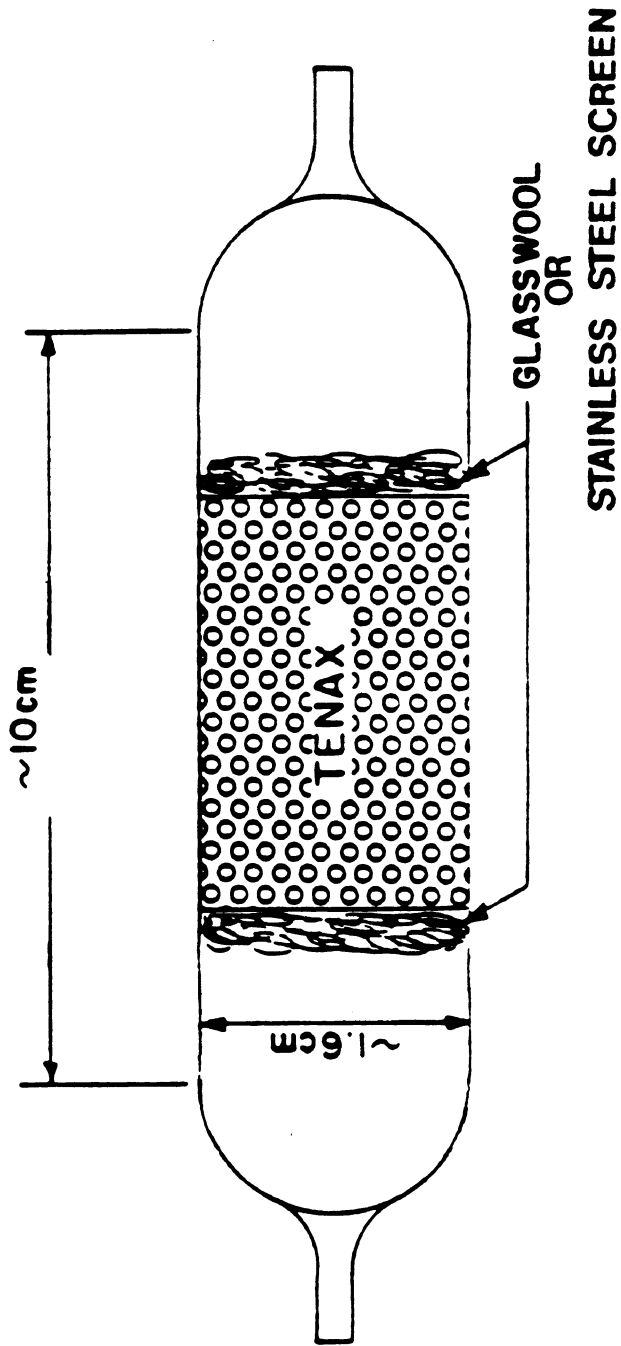
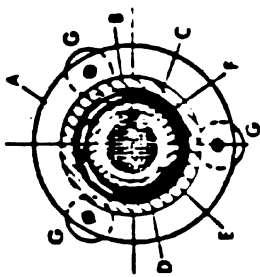

Figure 3. Inside-inside vost cartridge



**Section cut through glass tubes  
(showing screen, C-clip and O-ring in place)**

**LEGEND**

- A - Stainless Steel Carrier
- B - Glass Tube (9.84 L x 2.22 ID)
- C - Small Glass Tube (10 cm x 1.6 cm ID)
- D - Fine Mesh Stainless Steel Screen
- E - Stainless Steel C-Clip
- F - O-Ring (Viton)
- G - Nuts (+)
- H - End Cap with Viton O-Ring
- I - Metal Rod with Threaded End (3)
- J - Tenax/Charcoal Sorbent
- K - Cajon Fitting

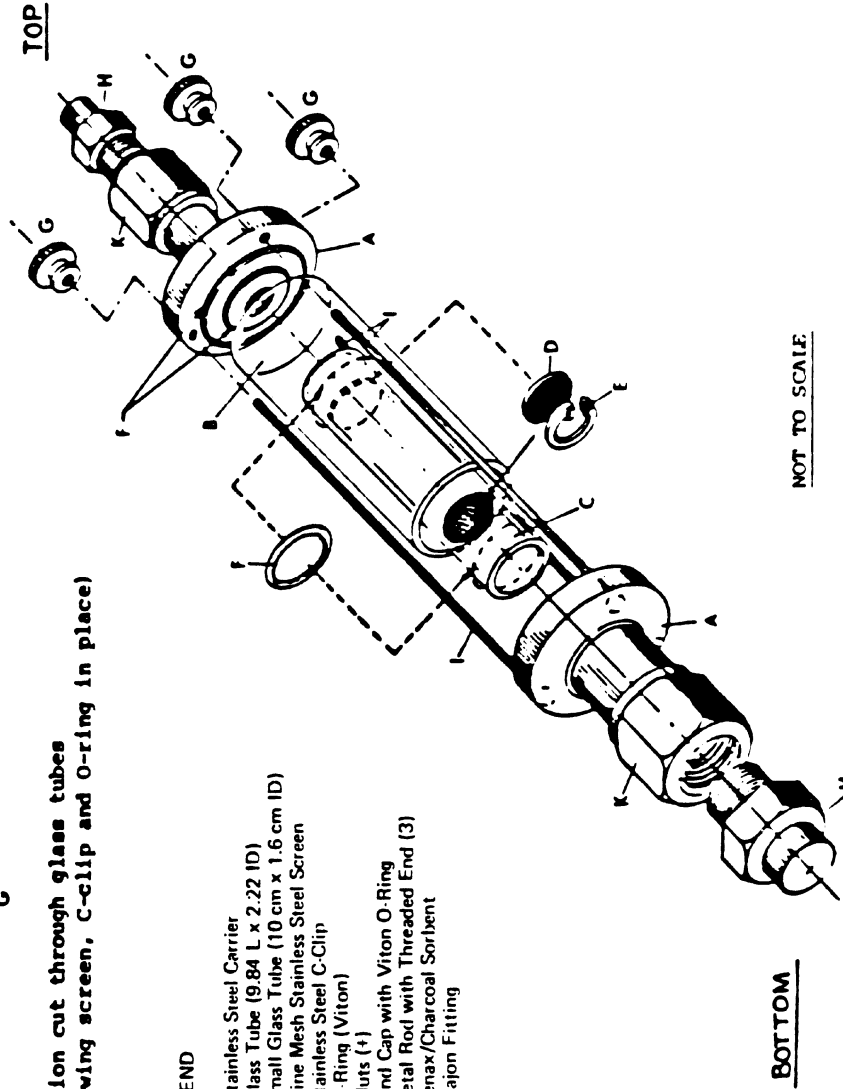

**BOTTOM**

**NOT TO SCALE.**

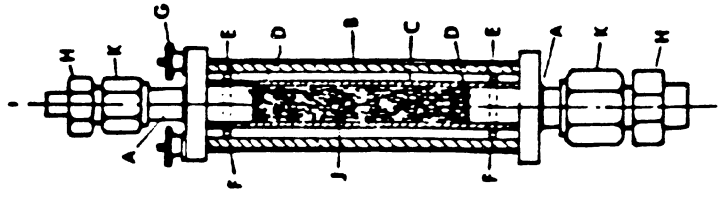

**Assembled Trap  
NTS**

**Figure 4. Sorbent Trap Assembly (I/O)  
Volatile Organic Sampling Train (VOST)**



All other sample transfer lines used with the VOST shall be Teflon with connecting fittings that are capable of forming leak-free, vacuum-tight connections without the use of sealing grease.

### 3.0 REAGENTS AND MATERIALS

#### 3.1 2,6-Diphenylene oxide polymer (Tenax, 35/60 mesh):

3.1.1 The new Tenax is Soxhlet extracted for 24 hr with methanol (Burdick & Jackson, pesticide grade or equivalent). The Tenax is dried for 6 hr in a vacuum oven at 50°C before use. Users of I/O and I/I sorbent cartridges have used slightly different thermal conditioning procedures. I/O sorbent cartridges packed with Tenax are thermally conditioned by flowing organic-free nitrogen (30 mL/min) through the resin while heating to 190°C. Some users have extracted new Tenax and charcoal with pentane to remove nonpolar impurities. However, these users have experienced problems with residual pentane in the sorbents during analysis.

3.1.2 If very high concentrations of volatile POHCs have been collected on the resin (e.g., micrograms of analytes), the sorbent may require Soxhlet extraction as described above. Previously used Tenax cartridges are thermally reconditioned by the method described above.

3.2 Charcoal (SKC petroleum-base or equivalent): New charcoal is prepared and charcoal is reconditioned as described in Paragraph 4.4. New charcoal does not require treatment prior to assembly into sorbent cartridges. Users of VOST have restricted the types of charcoal used in sorbent cartridges to only petroleum-based types. Criteria for other types of charcoal are acceptable if recovery of POHC in laboratory evaluations meet the criteria of 50 to 150%.

3.3 Viton-O-Ring: All O-rings used in VOST shall be Viton. Prior to use, these O-rings should be thermally conditioned at 200°C for 48 hr. O-rings should be stored in clean, screw-capped glass containers prior to use.

3.4 Glass tubes/Condensers: The glass resin tubes and condensers should be cleaned with a nonionic detergent in an ultrasonic bath, rinsed well with organic-free water, and dried at 110°C. Resin tubes of the I/O design should be assembled prior to storage as described in Paragraph 4.1. Resin tubes of the I/I design can be stored in glass culture tube containers with cotton cushioning and Teflon-lined screw caps. Condensers can be capped with appropriate end caps prior to use.

3.5 Metal parts: The stainless steel carriers, C-clips, end plugs, and screens used in the I/O VOST design are cleaned by ultrasonication in a warm nonionic detergent solution, rinsed with distilled water, air-dried, and heated in a muffle furnace for 2 hr at 400°C. Resin tubes of the I/I design require Swagelok or equivalent end caps with Supelco M-1 ferrules. These should be heated at 190°C along with the assembled cartridges.

3.6 Silica gel (Indicating type, 6-16 mesh): New silica gel may be used as received. Silica gel which has been previously used should be dried for 2 hr at 175°C (350°F).

3.7 Cold packs: Any commercially available reusable liquids or gels that can be repeatedly frozen are acceptable. They are typically sold in plastic containers as "Blue Ice" or "Ice-Packs." Enough should be used to keep cartridges at or near 4°C.

3.8 Water: Water used for cooling train components in the field may be tap water; and water used for rinsing glassware should be organic-free.

3.9 Glass wool: Glass wool should be Soxhlet extracted for 8 to 16 hr, using methanol, and oven dried at 110°C before use.

#### 4.0 SAMPLE HANDLING AND PROCEDURE

##### 4.1 Assembly:

4.1.1 The assembly and packing of the sorbent cartridges should be carried out in an area free of volatile organic material, preferably a laboratory in which no organic solvents are handled or stored and in which the laboratory air is charcoal filtered. Alternatively, the assembly procedures can be conducted in a glove box which can be purged with organic-free nitrogen.

##### 4.2 Tenax cartridges:

4.2.1 The Tenax, glass tubes, and metal cartridge parts are cleaned and stored (see Section 3.0). Approximately 1.6 g of Tenax is weighed and packed into the sorbent tube which has a stainless steel screen and C-clip (I/O design) or glass wool (I/I design) in the downstream end. The Tenax is held in place by inserting a stainless steel screen and C-clips in the upstream end (I/O design) or glass wool (I/I design). Each cartridge should be marked, using an engraving tool, with an arrow to indicate the direction of sample flow, and a serial number.

4.2.2 Conditioned resin tubes of the I/O design are then assembled into the metal carriers according to the previously described inside/inside or inside/outside procedures (with end caps) and are placed on cold packs for storage and transport. Conditioned resin tubes of the I/I design are capped and placed on cold packs for storage and transport.

##### 4.3 Tenax/Charcoal tubes

4.3.1 The Tenax, charcoal, and metal cartridge parts are cleaned and stored as previously described (see Section 3.0). The tubes are packed with approximately a 3:1 volume ratio of Tenax and charcoal (approximately 1 g each). The Tenax and charcoal are held in place by the stainless steel screens and C-clips (I/O design) or by glass wool (I/I design). The glass tubes containing the Tenax and charcoal are then

conditioned as described below (see Paragraph 4.4). Place the I/O glass tubes in the metal carriers (see Paragraph 2.1.4.2.2), put end caps on the assembled cartridges, mark direction of sample flow and serial number, and place the assembled cartridges on cold packs for storage and transport.

4.3.2 Glass tubes of the I/I design are conditioned, and stored in the same manner as the I/O tubes.

#### 4.4 Trap Conditioning - QC

4.4.1 Following assembly and leak-checking, the traps are connected in reverse direction to sampling to a source of organic-free nitrogen, and nitrogen is passed through each trap at a flow rate of 40 mL/min, while the traps are heated to 190°C for 12-28 hr. The actual conditioning period may be determined based on adequacy of the resulting blank checks.

4.4.2 The following procedure is used to blank check each set of sampling cartridges prior to sampling to ensure cleanliness. The procedure provides semi-quantitative data for organic compounds with boiling points below 110°C on Tenax and Tenax/Charcoal cartridges. It is not intended as a substitute for Method 5040.

4.4.2.1 The procedure is based on thermal desorption of each set of two cartridges, cryofocusing with liquid nitrogen onto a trap packed with glass beads, followed by thermal desorption from the trap and analysis by GC/FID.

4.4.2.2 The detection limit is based on the analysis of Tenax cartridges spiked with benzene and toluene and is around 2 ng for each compound.

4.4.2.3 The results of analyzing spiked cartridges on a daily basis should not vary by more than 20 percent. If the results are outside this range, the analytical system must be evaluated for the probable cause and a second spiked cartridge analyzed.

4.4.2.4 The GC operating conditions are as follows:

##### GC Operating Conditions

Column: Packed column 6 ft x 1/8" stainless steel 1.0 percent SP-1000 on Carbopack B 60/80, or equivalent.

Temperature program: 50°C for 5 min, 20°C/min increase to 190°C, hold 13 min.

Injector: 200°C.

Detector: F.I.D. 250°C.

Carrier Gas: Helium at 25 mL/min.

Sample valve: Valco 6-port with 40" x 1/16" stainless steel trap packed with 60/80 mesh glass beads.

Cryogen: Liquid nitrogen.

Trap heater: Boiling water, hot oil, or electrically heated.

Desorption heater: Supelco "clam shell" (high capacity carrier gas purifier) heater and Variac, adjusted to 180°C to 200°C.

4.4.2.5 Calibration is accomplished by preparing a spiked Tenax cartridge with benzene and toluene and analyzing according to the standard operating procedure. A standard of benzene, toluene and bromofluorobenzene (BFB) is prepared by injecting 2.0 uL of benzene and toluene and 1.0 uL of BFB into 10 mL of methanol. The concentration of this stock is 175 ng/uL of benzene and toluene, and 150 ng/uL BFB. One microliter of the stock standard is injected onto a Tenax cartridge through a heated injection port set at 150°C. A GC oven can be used for this with the oven at room temperature. Helium carrier gas is set at 50 mL/min. The solvent flush technique should be used. After two min, remove the Tenax cartridge and place in the desorption heater for analysis. BFB is also used as an internal standard spike for GC/MS analysis which provides a good comparison between GC/FID and GC/MS. The results of this spike analysis should not vary more than 20 percent day to day. Initially and then periodically this spiked Tenax should be reanalyzed a second time to verify that the 10 min desorption time and 180-200°C temperature are adequate to remove all of the spiked components. It should be noted that only one spiked Tenax cartridge need be prepared and analyzed daily unless otherwise needed to ensure proper instrument operation.

An acceptable blank level is left to the discretion of the method analyst. An acceptable level is one that allows adequate determination of expected components emitted from the waste being burned.

4.4.3 After conditioning, traps are sealed and placed on cold packs until sampling is accomplished. Conditioned traps should be held for a minimum amount of time to prevent the possibility of contamination.

4.4.4 It may be useful to spike the Tenax and Tenax/charcoal traps with the compounds of interest to ensure that they can be thermally desorbed under laboratory conditions. After spiked traps are analyzed they may be reconditioned and packed for sampling.

#### 4.5 Pretest preparation:

4.5.1 All train components shall be cleaned and assembled as previously described. A dry gas meter shall have been calibrated within 30 days prior to use, using an EPA-supplied standard orifice.

4.5.2 The VOST is assembled according to the schematic diagram in Figure 1. The cartridges should be positioned so that sample flow is

through the Tenax first and then the Tenax/charcoal. Cooling water should be circulated to the condensers and the temperature of the cooling water should be maintained near 0°C. The end caps of the sorbent cartridges should be placed in a clean screw-capped glass container during sample collection.

#### 4.6 Leak-checking:

4.6.1 The train is leak-checked by closing the valve at the inlet to the first condenser and pulling a vacuum of 250 mm (10 in. Hg) above the normal operating pressure. The traps and condensers are isolated from the pump and the leak rate noted. The leak rate should be less than 2.5 mm Hg after 1 min. The train is then returned to atmospheric pressure by attaching a charcoal-filled tube to the train inlet and admitting ambient air filtered through the charcoal. This procedure will minimize contamination of the VOST components by excessive exposure to the fugitive emissions at hazardous waste incinerator sites.

#### 4.7 Sample Collection

4.7.1 After leak-checking, sample collection is accomplished by opening the valve at the inlet to the first condenser, turning on the pump, and sampling at a rate of 1 liter/min for 20 min. The volume of sample for any pair of traps should not exceed 20 liters.

4.7.2 Following collection of 20 liters of sample, the train is leak-checked a second time at the highest pressure drop encountered during the run to minimize the chance of vacuum desorption of organics from the Tenax. The train is returned to atmospheric pressure, using the method discussed in Paragraph 4.1 and the two sorbent cartridges are removed. The end caps are replaced and the cartridges shall be placed in a suitable environment for storage and transport until analysis. The sample is considered invalid if the leak test does not meet specification.

4.7.3 A new pair of cartridges is placed in the VOST, the VOST leak-checked, and the sample collection process repeated as described above. Sample collection continues until six pairs of traps have been used.

4.7.4 All sample cartridges should be kept on cold packs until they are ready for analysis.

#### 4.8 Blanks

4.8.1 **Field blanks/trip blanks:** Blank Tenax and Tenax/charcoal cartridges are taken to the sampling site and the end caps removed for the period of time required to exchange two pairs of traps on VOST. After the two VOST traps have been exchanged, the end caps are replaced on the blank Tenax and Tenax/charcoal tubes and these are returned to the cold packs and analyzed with the sample traps. At least one pair of field blanks (one Tenax, one Tenax/charcoal) shall be included with each

six pairs of sample cartridges collected (or for each field trial using VOST to collect volatile POHCs).

**4.8.2 Trip blanks:** At least one pair of blank cartridges (one Tenax, one Tenax/charcoal) shall be included with shipment of cartridges to a hazardous waste incinerator site. These "field blanks" will be treated like any other cartridges except that the end caps will not be removed during storage at the site. This pair of traps will be analyzed to monitor potential contamination which may occur during storage and shipment.

**4.8.3 Laboratory blanks:** One pair of blank cartridges (one Tenax, one Tenax/charcoal) will remain in the laboratory using the method of storage which is used for field samples. If the field and trip blanks contain high concentrations of contaminants (e.g., greater than 2 ng of a particular POHC), the laboratory blank shall be analyzed in order to identify the source of contamination.

## 5.0 CALCULATIONS (for sample volume)

5.1 The following nomenclature are used in the calculation of sample volume:

$P_{bar}$  = Barometric pressure at the exit orifice of the dry gas meter, mm (in.) Hg.

$P_{std}$  = Standard absolute pressure, 760 mm (29.92 in.) Hg.

$T_m$  = Dry gas meter average absolute temperature, K (°R).

$T_{std}$  = Standard absolute temperature, 293K (528°R).

$V_m$  = Dry gas volume measured by dry gas meter, dcm (dcf).

$V_{m(std)}$  = Dry gas volume measured by dry gas meter, corrected to standard conditions, dscm (dscf).

$\gamma$  = Dry gas meter calibration factor.

5.2 The volume of gas sampled is calculated as follows:

$$V_{m(std)} = V_m \gamma \frac{T_{std} P_{bar}}{T_m P_{std}} = K_1 \gamma \frac{V_m P_{bar}}{T_m}$$

where:

$K_1 = 0.3858 \text{ K/mm Hg}$  for metric units, or

$K_1 = 17.64 \text{ °R/in. Hg}$  for English units.

## 6.0 ANALYTICAL PROCEDURE

See Method 5040.

## 7.0 PRECISION AND ACCURACY REQUIREMENTS

### 7.1 Method Performance Check

Prior to field operation of the VOST at a hazardous waste incinerator, a method performance check should be conducted using either selected volatile POHCs of interest or two or more of the volatile POHCs for which data are available. This check may be conducted on the entire system (VOST/GC/MS) by analysis of a gas cylinder containing POHCs of interest or on only the analytical system by spiking of the POHCs onto the traps. The results of this check for replicate pairs of traps should demonstrate that recovery of the analytes fall within 50% to 150% of the expected values.

### 7.2 Performance Audit

During a trial burn a performance audit must be completed. The audit results should agree within 50% to 150% of the expected value for each specific target compound. This audit consists of collecting a gas sample containing one or more POHCs in the VOST from an EPA ppb gas cylinder. Collection of the audit sample in the VOST may be conducted either in the laboratory or at the trial burn site. Analysis of the VOST audit sample must be by the same person, at the same time, and with the same analytical procedure as used for the regular VOST trial burn samples. EPA ppb gas cylinders currently available for VOST Audit are shown in Table 1 below.

The audit procedure, audit equipment and audit cylinder may be obtained by writing:

Audit Cylinder Gas Coordinator (MD-77B)  
Quality Assurance Division  
Environmental Monitoring Systems Laboratory  
U.S. Environmental Protection Agency  
Research Triangle Park, NC 27711

or by calling the Audit Cylinder Gas Coordinator at (919) 541-4531.

The request for the audit must be made at least 30 days prior to the scheduled trial burn. If a POHC is selected for which EPA does not have an audit cylinder, this audit is not required.

## 8.0 REFERENCES

1. Protocol for the Collection and Analysis of Volatile POHCs Using VOST. EPA/600/8-84/007, March 1984.
2. Sykes, A.L., Standard Operating Procedure for Blanking Tenax and Tenax/Charcoal Sampling Cartridges for Volatile Organic Sampling Train (VOST), Radion Corporation, P.O. Box 13000, Research Triangle Park, NC 27709.
3. Validation of the Volatile Organic Sampling Train (VOST) Protocol, Vols. I and II, EPA/600/4-86/014a, January 1986.



TABLE 1: Organic Gases in the ppb Audit Repository

---

<u>Group I</u>	<u>Ranges of cylinders currently available:</u>
5 Organics in N <sub>2</sub> :	7 - 90 ppb
Carbon tetrachloride	90 - 430 ppb
Chloroform	430 - 10,000 ppb
Perchloroethylene	
Vinyl chloride	
Benzene	

---

<u>Group II</u>	<u>Ranges of cylinders currently available:</u>
9 Organics in N <sub>2</sub>	7 - 90 ppb
Trichloroethylene	90 - 430 ppb
1,2-Dichloroethane	
1,2-Dibromoethane	
F-12	
F-11	
Bromomethane	
Methyl ethyl ketone	
1,1,1-Trichloroethane	
Acetonitrile	

TABLE 1: Organic Gases in the ppb Audit Repository (Continued)

---

<u>Group III</u>	<u>Ranges of cylinders currently available:</u>
7 Organics in N <sub>2</sub> :	7 - 90 ppb
Vinylidene chloride	90 - 430 ppb
F-113	
F-114	
Acetone	
1,4-Dioxane	
Toluene	
Chlorobenzene	

---

<u>Group IV</u>	<u>Ranges of cylinders currently available:</u>
6 Organics in N <sub>2</sub> :	7 - 90 ppb
Acrylonitrile	430 - 10,000
1,3-Butadiene	
Ethylene oxide	
Methylene chloride	
Propylene oxide	
Ortho-xylene	

---

CD-ROM

0030 - 18

Revision 0  
Date September 1986